



#972

ANTHONY CRANE RENTAL

Telescopic Truck Crane

LTM 1120

Telescopic boom 148 ft



LIEBHERR

Lifting capacities at telescopic boom. Forces de levage à la flèche télescopique.

LTM 1120



46 ft - 148 ft



360°



63300 lbs



85%

ft	46 ft	62 ft	72 ft	77 ft	93 ft	108 ft	124 ft	139 ft	148 ft	ft		
9	330									9		
10	282	242								10		
11	256	230								11		
12	234	218	180							12		
13	216	207	182							13		
14	202	197	181	143						14		
15	188	187	179	145	129	86				15		
16	176	171	147	129	86.5					16		
17	166	164	146	129	87	92.5				17		
18	157	155	142	128	88	93				18		
20	140	139	134	126	89.5	93.5	71	63.5		20		
22	127	126	124	119	89.5	94	71.5	61.5		22		
24	116	114	114	112	87.5	93.5	71.5	59.5	59.6	24		
26	106	104	104	103	83	91	72	56.8	59.4	26		
28	98	96.5	96	95.5	79.5	87.5	71	54.4	58.9	45.4	38.3	28
30	90.5	89	88.5	88	76	83.5	69.5	52.1	58.3	45.3	37.7	30
32	84.5	82.5	82	82	73	79.5	68	50.1	57.5	45.2	37.1	32
34		77.5	76.5	76.5	70	75.5	66	48.2	56.3	44.8	36.4	34
36		72.5	72	71.5	67.5	71.5	64	46.4	54.8	44.3	35.6	36
38		68	67	67	65	67.5	62	44.6	53.2	43.8	34.8	38
40		63.5	63	62.5	62.5	63.5	59.7	43	51.7	43.1	33.9	40
45		54.9	53.8	53.1	57.2	54.5	54.6	39.5	47.8	40.3	31.7	45
50		44.5	46.3	45.5	52.2	47	48.2	36.4	44.2	37.7	29.3	50
55			40	39.2	47	40.7	42.1	33.5	40.6	35.2	27	55
60				33.9	41.8	35.4	36.8	30.9	36.8	32.8	24.8	60
65				29.6	37.4	31	32.4	28.7	32.5	30.4	22.8	65
70						27.4	28.7	26.8	28.9	28.4	20.9	70
75						24.1	25.4	25.1	25.8	26	19.2	75
80							22.5	23.7	23	23.3	17.6	80
85							20	22.4	20.7	21	16.1	85
90							17.6	21.3	18.5	19	14.8	90
95							15.4	20	16.4	17	13.8	95
100									14.6	15.2	13	100
105									12.9	13.5	11.9	105
110									11.5	12	11.1	110
115										10.7	10.3	115
120										9.6	9.4	120
125											8.4	125
130											7.6	130
I	0	46	77	92	0	92	92	0	92	92	100	I
II	0	0	0	0	46	23	46	92	69	92	100	II
III	0	0	0	0	46	23	46	92	69	92	100	III

over rear / en arrière

TAB 93120/93122

Remarks referring to load charts.

- The tabulated lifting capacities do not exceed 85 % of the tipping load.
- The crane's structural steelwork is in accordance with DIN 15018, part 3. Design and construction of the crane comply with DIN 15018, part 2, and with F. E. M. regulations.
- The 85 % overturning limit values take into account wind force 5 = wind speed 20 mph.
- Lifting capacities are given in kips.
- The weight of the hook blocks and hooks must be deducted from the lifting capacities.
- Working radii are measured from the slewing centreline.
- The lifting capacities given for the telescopic boom only apply if the folding jib is taken off.
- Lifting capacities are subject to modifications.
- Lifting capacities above 268 kips only with special equipment.

Remarques relatives aux tableaux des charges.

- Les forces de levage indiquées ne dépassent pas 85 % de la charge de basculement.
- La norme DIN 15018, 3ème partie est appliquée pour les charpentes. La construction de la grue est réalisée conformément à la norme DIN 15018, 2ème partie, et aux règles de la F. E. M.
- A 85 % de la charge de basculement, il a été tenu compte d'un vent de force 5 = vitesse de vent 20 mph.
- Les forces de levage sont données en kips.
- Le poids des moufles et crochets doit être soustrait des charges indiquées.
- Les portées sont calculées à partir de l'axe de rotation.
- Les forces indiquées pour la flèche télescopique s'entendent fléchette déployable déposée.
- Les forces de levage sont modifiables sans préavis.
- Forces de levage plus de 268 kips seulement avec équipement supplémentaire.

Lifting capacities are given in kips (1,000 lbs).



46 ft - 148 ft



360°

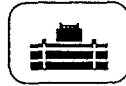

42300 lbs

85%

ft	46 ft		62 ft	72 ft	77 ft		93 ft	108 ft		124 ft	139 ft	148 ft	ft
10	261	240											10
11	241	228											11
12	222	215	180										12
13	205	202	182										13
14	191	190	180	143									14
15	178	175	145	129	86								15
16	167	165	147	129	86.5								16
17	157	156	145	129	87	92.5							17
18	149	147	140	128	88	93							18
20	133	131	130	125	89.5	93.5	71	63.5					20
22	120	119	118	116	89.5	94	71.5	61.5					22
24	110	108	107	107	87.5	93.5	71.5	59.5	59.6				24
26	100	98.5	98	97.5	83	91	72	56.8	59.4				26
28	92.5	91	90	90	79.5	87.5	71	54.4	58.9	45.4	37.6		28
30	85.5	83.5	83	82.5	76	82.5	69.5	52.1	58.3	45.3	37.5		30
32	79.5	78	77	76	73	75.5	68	50.1	57.5	45.2	37		32
34		72.5	71	70	70	69.5	65	48.2	56.3	44.8	36.4		34
36		67.5	65.5	64.5	67.5	64	61	46.4	54.8	44.3	35.6		36
38		63	60	58.6	65	58.4	57.1	44.6	53.2	43.8	34.8		38
40		58.3	55.2	53.5	62	53.6	53.3	43	51.2	43.1	33.9		40
45		48.6	45.4	44	53.5	44.5	44.6	39.5	43.9	40.3	31.7		45
50		40.2	38.1	36.8	46.2	37.5	37.9	36.4	37.6	36.5	29.3		50
55			31.9	30.9	39.8	31.8	32.4	33.5	32.3	32.3	27		55
60				26	34.3	27.1	27.8	30.9	27.9	28	24.8		60
65				21.5	29.8	23.4	24.1	28.7	24.3	24.6	22.8		65
70						20.1	21.1	26.5	21.3	21.6	20.9		70
75						17.2	18.4	24.1	18.7	19.1	18.7		75
80							15.9	21.5	16.4	16.8	16.5		80
85							13.7	19.2	14.4	14.9	14.6		85
90							11.8	17.2	12.5	13.1	12.9		90
95							10	15.5	10.7	11.4	11.2		95
100									9.2	9.9	9.7		100
105									8	8.6	8.4		105
110									6.9	7.5	7.4		110
115										6.6	6.4		115
120										5.6	5.5		120
125											4.7		125
130											3.8		130
I	0	46	77	92	0	92	92	0	92	92	100	I	
II	0	0	0	0	46	23	46	92	69	92	100	II	
% III	0	0	0	0	46	23	46	92	69	92	100	III %	

" over rear / en arrière

TAB 93121 / 93123

Les forces de levage sont données en kips (1,000 lbs).

Lifting heights. Hauteurs de levage.

LTM 1120

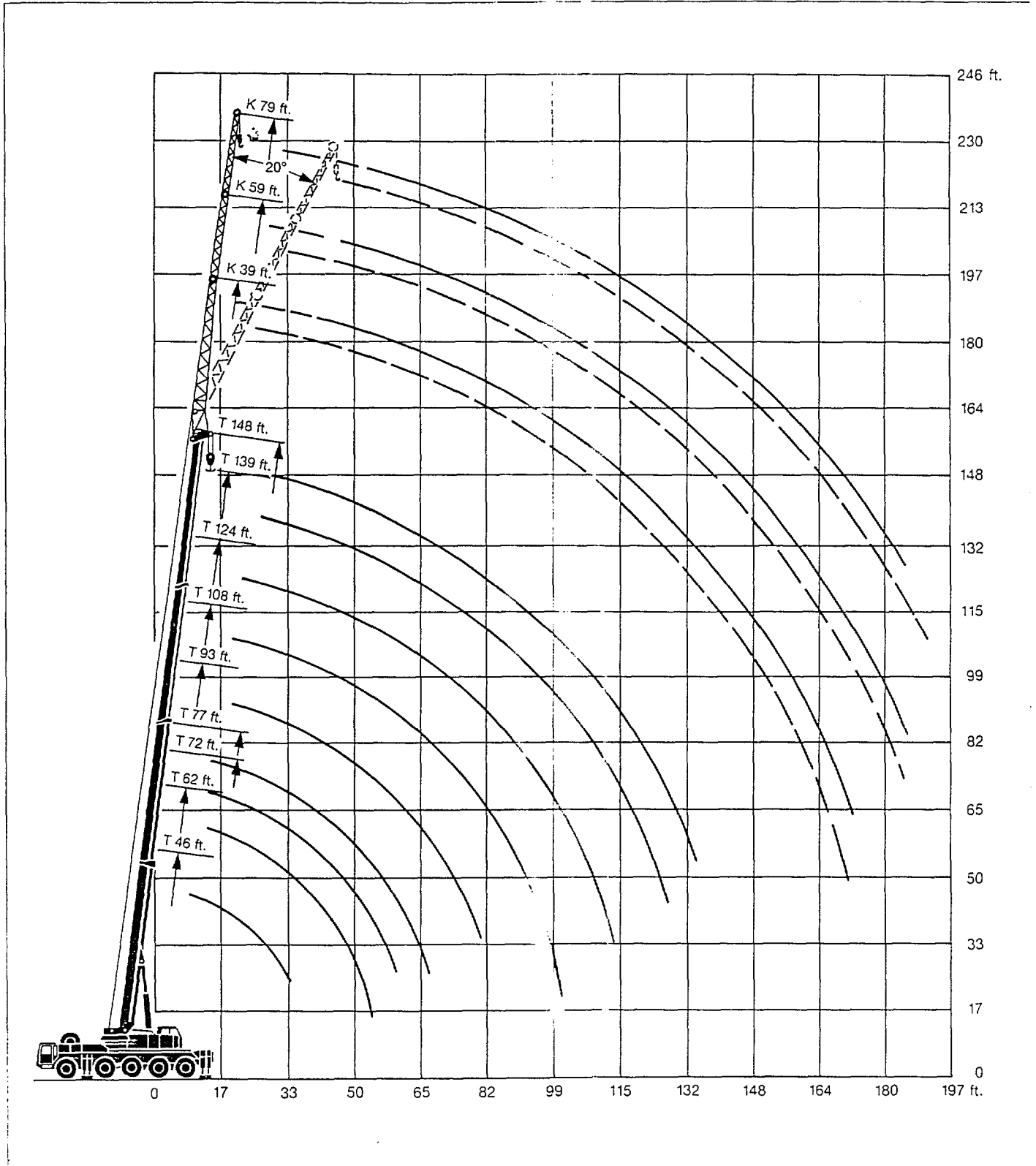

Lifting capacities at the folding jib. Forces de levage à la fléchette pliante.

LTM 1120



108 ft - 148 ft

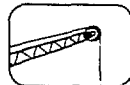

0°
39 ft - 98 ft

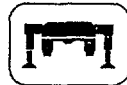

360°



63300 lbs

95%

ft	124 ft	139 ft	148 ft	108 ft	139 ft	148 ft	139 ft	148 ft	ft
	39 ft	39 ft	39 ft	59 ft	59 ft	59 ft	79 ft	79 ft	
34	30.1	24.9		19.2					34
36	30.2	24.9		18.9					36
38	30.3	24.8		18.6					38
40	30.3	24.8	21.6	18.2	16.2				40
45	30.4	24.5	21.2	17.4	15.8				45
50	29.2	23.9	20.5	16.7	15.3	14.3	10.3		50
55	27.5	22.8	19.4	15.9	14.9	14.1	10	9.6	55
60	25.7	21.3	18	15.2	14.4	13.7	9.7	9.4	60
65	24.2	20	16.7	14.5	13.9	13.2	9.5	9.2	65
70	22.8	18.8	15.6	13.9	13.5	12.4	9.2	9	70
75	21.5	17.8	14.7	13.1	13	11.6	9	8.7	75
80	20.4	16.7	13.8	12.2	12.6	10.9	8.7	8.5	80
85	19.3	15.8	13	11.5	12.2	10.3	8.5	8.2	85
90	18.4	15	12.2	10.9	11.7	9.8	8.2	7.9	90
95	17.2	14.2	11.4	10.3	11.2	9.3	8	7.5	95
100	15.8	13.5	10.6	9.8	10.6	8.9	7.8	7.2	100
105	14.2	12.9	9.9	9.3	10.1	8.4	7.6	6.9	105
110	12.7	12.3	9.3	8.9	9.7	7.9	7.4	6.6	110
115	11.3	11.1	8.8	8.5	9.3	7.5	7.3	6.3	115
120	10.1	10	8.3	8.1	9	7.1	7.1	5.9	120
125	9.1	9	7.7	7.8	8.7	6.7	6.9	5.6	125
130	8.3	8.2	7.2	7.5	8.4	6.3	6.8	5.2	130
135	7.5	7.4	6.6	7.3	8	6	6.6	4.9	135
140	6.8	6.7	6.2	7	7.5	5.7	6.5	4.7	140
145	6.1	6	5.7	6.8	6.8	5.4	6.2	4.4	145
150	5.4	5.4	5.1	6.6	6.2	5.1	5.9	4.2	150
155		4.8	4.5	6.4	5.6	4.9	5.7	3.9	
160		4.2	3.9		5.1	4.6	5.4	3.7	
165			3.4		4.6	4.3	4.9	3.5	
170			2.8		4.1	3.8	4.4	3.4	
175					3.5	3.3	4	3.2	
180					3	2.8	3.5	3	
185							3.1	2.8	
190							2.7	2.4	

TAB 83086



108 ft - 148 ft

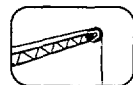

20°
39 ft - 98 ft



360°



63300 lbs



85%

ft	124 ft	139 ft	148 ft	108 ft	139 ft	148 ft	139 ft	148 ft	ft
	39 ft	39 ft	39 ft	59 ft	59 ft	59 ft	79 ft	79 ft	
40	20.2	15.6		12.7					40
45	19.2	14.9		12					45
50	18.4	14.2	11.3	11.4					50
55	17.7	13.6	10.8	10.8	10.5	8.5			55
60	17	13	10.4	10.3	10.1	8.2	7.6	6.6	60
65	16.4	12.5	10	9.9	9.7	7.9	7.4	6.4	65
70	15.8	12	9.6	9.4	9.4	7.6	7.3	6.1	70
75	15.3	11.6	9.2	9.1	9.1	7.3	7.1	5.9	75
80	14.8	11.2	8.8	8.7	8.8	7.1	7	5.7	80
85	14.3	10.9	8.3	8.4	8.5	6.9	6.8	5.5	85
90	13.8	10.5	7.9	8.2	8.3	6.6	6.7	5.3	90
95	13.4	10.2	7.5	7.9	8.1	6.5	6.6	5.1	95
100	13	10	7.1	7.7	7.9	6.3	6.4	5	100
105	12.7	9.7	6.8	7.5	7.7	6.1	6.2	4.8	105
110	12.5	9.5	6.6	7.3	7.5	5.9	5.9	4.7	110
115	11.9	9.3	6.3	7.1	7.4	5.8	5.8	4.5	115
120	10.9	9.2	6.1	6.9	7.2	5.6	5.7	4.4	120
125	9.7	9	5.8	6.8	7.1	5.4	5.6	4.3	125
130	8.8	8.8	5.6	6.7	6.9	5.2	5.5	4.2	130
135	8	8.2	5.5	6.5	6.8	5	5.4	4.1	135
140	7.2	7.4	5.3	6.4	6.7	4.8	5.3	4	140
145		6.7	5.2	6.3	6.6	4.6	5.2	3.8	145
150		6	5.1	5.3	6.4	4.5	5.1	3.7	150
155		5.3	4.9		6.2	4.3	5	3.6	155
160		4.6	4.5		5.7	4.2	4.9	3.4	160
165			3.9		5.1	4.1	4.8	3.3	165
170			3.2		4.6	3.9	4.7	3.1	170
175					4	3.7	4.6	3	175
180					3.4	3.3	4.2	2.8	180
185							3.7	2.7	185
190							3.3	2.6	190
195							2.7	2.5	195

Dimensions. Encombrement.

LTM 1120

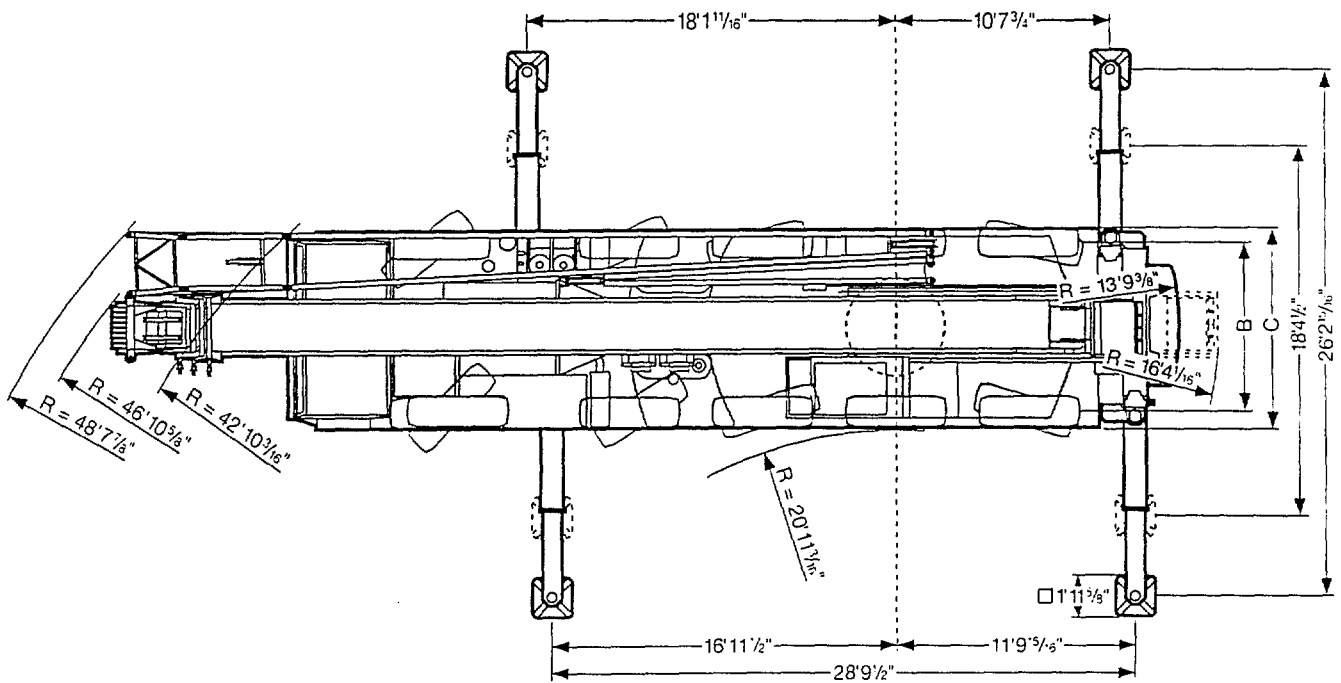
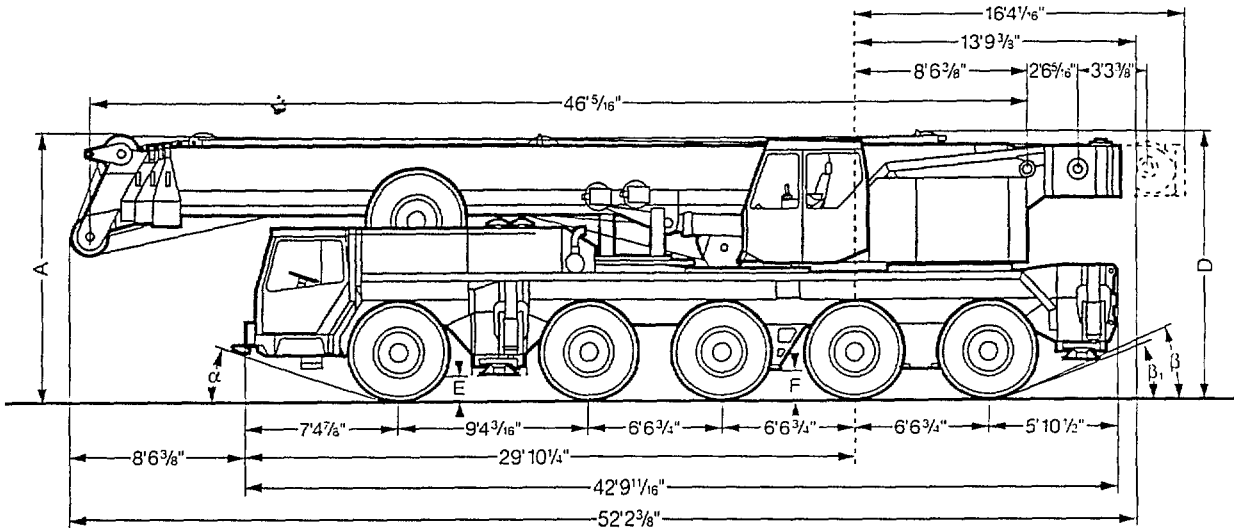

16.00 R 25	Dimensions / Encombrement mm								
	A	A*	B	C	D	E	F	a	β
	12'9 1/2"	12'3 1/2"	8'4 1/4"	9'10"	12'5 1/2"	14 3/4"	18'2"	23°	25°

* lowered / abaissé

Weights. Poids.

LTM 1120



Axle Essieu	1	2	3	4	5	Total weight Poids total
lbs	26500	26500	26500	26500	26500	132500





with 3960 lbs counterweight and 3300 lbs substitute ballast resp. hoisting gear 2
avec contrepoids 3960 lbs et contrepoids de remplacement 3300 lbs resp. deuxième mécanisme de levage







Load (kips) Forces de levage (kips)	No. of sheaves Poulies	No. of lines Brins	Weight lbs Poids lbs
264.6	8	17	2447
220.5	7	14	2161
180.8	5	11	1940
119	3	7	1146
52.9	1	3	882
17.6	-	1	419

Working speeds. Vitesses.



	1	2	3	4	5	R	
 mph	8	13	20.5	30.2	43	9.4	26%
 mph 	4.5	7.5	12	17.2	24.7	5.3	48%
	16.00 R 25						



Drive Mécanismes	infinitely variable en continu	Rope diameter / Rope length Diamètre du câble / Longueur du câble	Max. single line pull Effort au brin maxi.
	0 - 395 ft/min single line ft/min au brin simple	1 3/16" / 820'	17625 lbs
	0 - 395 ft/min single line ft/min au brin simple	1 3/16" / 738'	17625 lbs
	0 - 2.0 rpm		
	approx. 50 seconds to reach 83° boom angle env. 50 s jusqu'à 83°		
	approx. 150 seconds for boom extension from 46 ft - 148 ft env. 150 s pour passer de 46 ft - 148 ft		

Truck chassis.

- Frame:** Liebherr designed and manufactured, box type, torsion resistant, all-welded construction made of high-tensile structural steel.
- Outriggers:** 4 sliding beams with hydraulic extension cylinders and hydraulic support pad jacks. Front outriggers mounted between axles 1 and 2, rear outriggers at rear of truck chassis.
- Engine:** Diesel, 8 cylinder, watercooled, make Daimler-Benz, type OM 442 LA, output 353 kW DIN (480 HP) at 2100 rpm, max. torque 1473 lbs-ft at 1000 - 1600 rpm. Fuel tank capacity: 185 gallons.
- Transmission:** Allison type CLBT 754 automatic transmission with torque converter and hydrodynamic retarder brake. 5 forward speeds, 1 reverse. Transfer box with front wheel drive engagement and off-road range.
- Axles:** Heavy duty crane truck axles, all 5 axles sprung. Axles 1, 2, 3 and 5 steered. Axles 1, 4 and 5 have planetary reduction gears and inter-axle differentials.
- Suspension:** All axles are hydropneumatically sprung with automatic levelling. Load equalization between axles 1 and 2, single axle 3 and axles 4 and 5. Suspension hydraulically locked.
- Tyres:** 10 tyres, all axles with single tyres. Tyre size: 16.00 R 25.
- Steering:** ZF semi-unitary hydraulic power steering, dual circuit system, with hydraulic servo mechanism and auxiliary pump circuit.
- Brakes:** Service brake: servo assisted air brakes acting on all wheels, dual circuit system. Hand brake: spring-action, acting on all wheels of axles 2 to 5.
- Driver's cab:** Large-area, all-steel cab with resilient mountings, safety glass windows and full range of instruments.
- Electrical system:** 24 Volts DC, 2 batteries, lighting to German road vehicle regulations.

Crane superstructure.

- Frame:** Liebherr-made, torsion-resistant, welded construction made of high-tensile structural steel. Connection to truck chassis by triple roller slewing ring, designed for 360° continuous rotation.
- Crane engine:** Diesel, 6 cylinder, watercooled, make Daimler-Benz, type OM 366 A, output 121 kW DIN (165 HP) at 2300 rpm, max. torque 415 lbs-ft at 1500 rpm. Fuel tank capacity: 74 gallons.
- Crane drive:** Diesel-hydraulic, with 1 duplex axial-piston pump with automatic output control 1 duplex gear-type pump, open hydraulic circuits.
- Crane control:** By self-centering control lever, movable in 4 directions (cross-control arrangement).
- Main winch:** Axial piston motor, full hydraulic power up and down. Hoist drum with integrated planetary gear and spring loaded brake.
- Luffing gear:** Twin double-acting hydraulic cylinder with integral safety locking valves.
- Slewing gear:** Planetary gear with flange connected hydraulic motor and spring loaded brake.
- Crane cab:** All-steel construction, safety glazing, controls and instruments.
- Safety devices:** LICCON overload safety indicator, hoist limit switch, safety valves to protect hydraulic system against pipe and hose fracture.
- Telescopic boom:** 1 boom pivot section and 3 telescopic sections; can be extended hydraulically under partial load. Telescopic section 1 can be hydraulically extended independently, telescopic sections 2 and 3 can be extended with synchronised action. Boom length: 46 ft - 148 ft.
- Electrical system:** 24 Volts DC, 2 batteries.

Additional equipment.

- Folding jib:** 39 ft - 98 ft long, for straight-line boom extension.
- Hoisting gear 2:** For two-hook operation.

Other items of equipment available on request.